

ART.3012

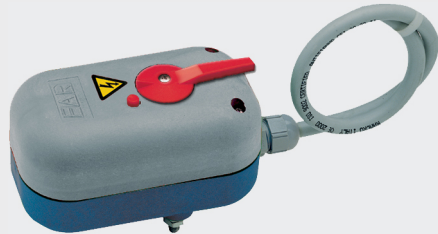

SMALL - Electric modulating actuator with manual release for ball mixing valve.

- External connection cable length: 1 m.
- Feed voltage: 24V 50Hz
- Rotation angle: 90°
- Rotation time: 180 seconds
- Protection level: IP54
- Analog control input: 0-10V or 4-20mA
- Torque: 10Nm

ART.301220

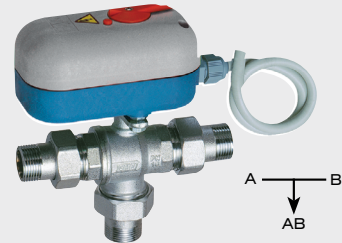

Chrome-plated 3-way mixing zone control ball valve equipped with unions, nuts and 0-10V electronic modulating actuator, 24 V.

- Connections: male-male
- Full bore flow

1 DESCRIPTION

The modulating actuator, consisting of a gearmotor, allows the movement of a mixing valve in a completely automatic way, taking the signal from a thermostat with modulating regulation or from a control unit working with a 0-10V or 4-20mA analogic signal. It's possible to know the valve position thanks to an indicator.

2 INSTALLATION

The actuator can only be installed on Far zone valves, both horizontally and vertically.

- ⚠ Avoid installing the actuator upside down, as it's not suitable to be used in stagnant water.**
⚠ The IP54 protection degree means that the actuator is protected against dust and water spraying.

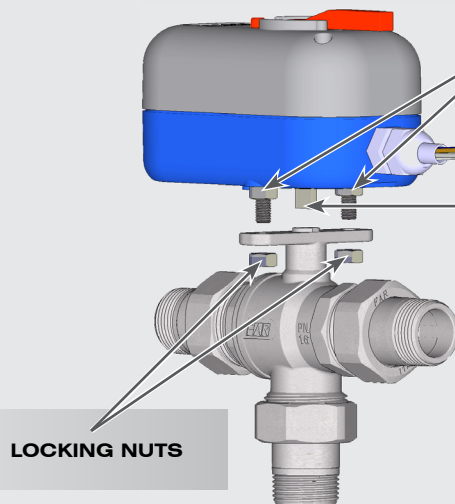

⚠ DO NOT REMOVE THE TWO NUTS

ACTUATOR PIN

Place the valve so that the actuator pin and the stem on the valve correspond.

Place the stud bolts in the corresponding holes on the valve flange and lock with the provided nuts.

MANUAL RELEASE

Press the red button and at the same time turn the switch connected to the crankshaft by 90° clockwise or anticlockwise in order to place the engine in the desired position. Normal operation resumes automatically.

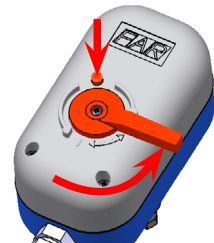

3 MIXING VALVE AND ELECTRICAL CONNECTION OF THE ACTUATOR

The 3-way mixing valve is a full bore ball valve. The valve bodies are available with male-male connections and 1/2", 3/4", 1" and 1 1/4" size. It's necessary to provide an electronic regulation with 0-10V or 4-20mA signal in order to operate the mixing valve. When correctly connected to the actuator, the valve adjusts the ball position in order to get the mixed fluid at the desired temperature, thanks to the signal of a sensor placed at the valve outlet.

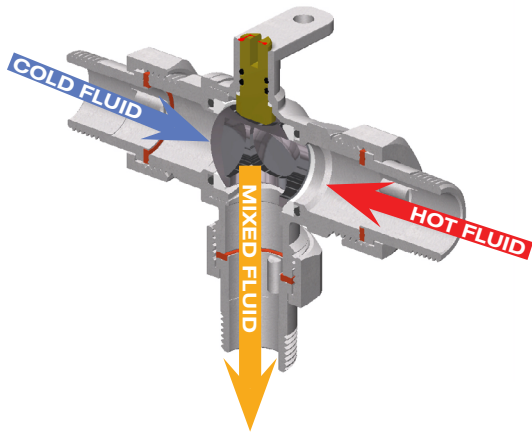

Here below is shown the wiring diagram of the actuator art.3012 180, where the cable colors are indicated in order to connect them in the right way. The actuator must be supplied with 24V AC power by connecting the BLUE cable to neutral and the BROWN cable to phase. The GREY cable must also be connected to phase in order to determine the opening starting point. In this case, when connecting the GREY cable to phase with driving voltage 0V, the valve is in position **A**, while with 10V the valve is in position **B**.

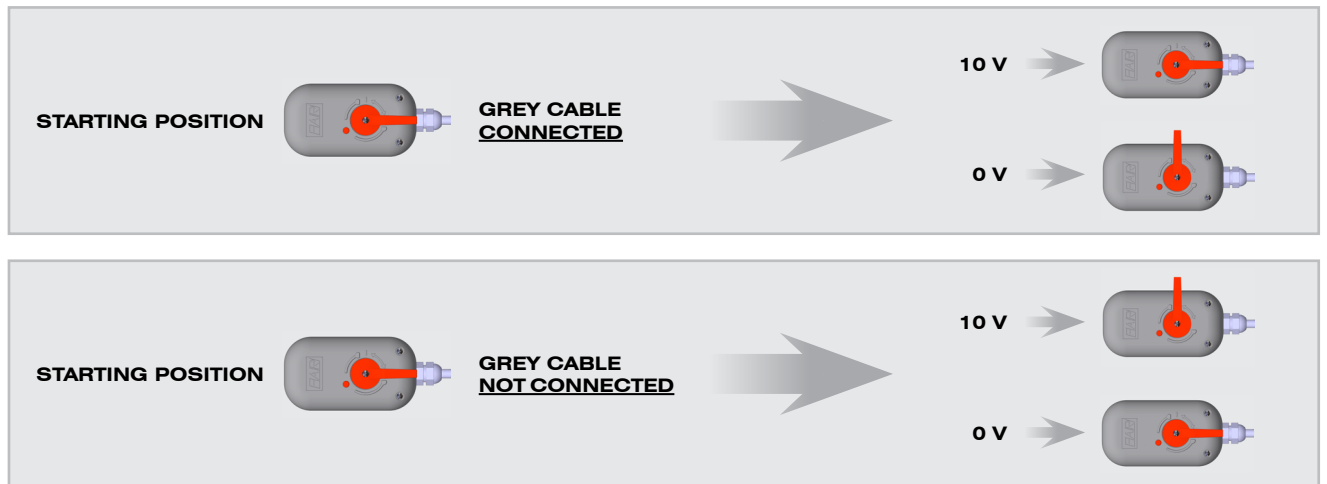
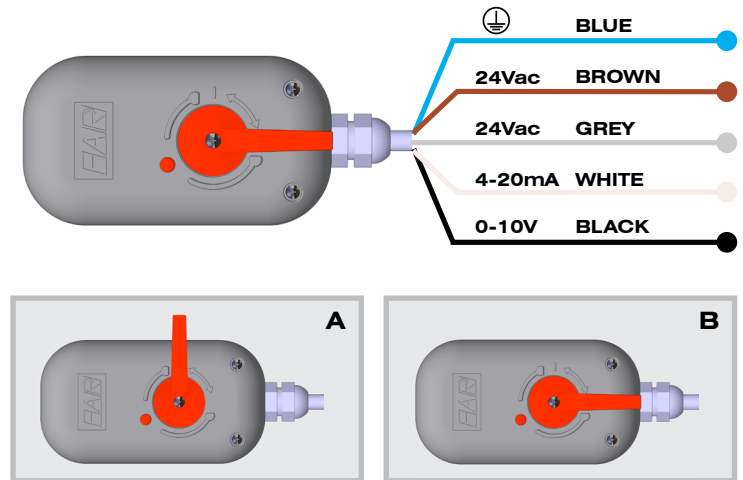

⚠ Before connecting the actuator make sure that the selected model is compatible with the available network voltage. All the connections must be done by qualified staff following the electric diagram (shown on the actuator) and making sure that the main electric supply line is off. Any wrong connections may damage both the person and the equipment.

| COLOUR | CONNECTION | DESCRIPTION |
|--------|------------|--|
| BLUE | NEUTRAL | NEUTRAL CONNECTION - ACTUATOR POWER SUPPLY |
| BROWN | PHASE | 24Vac PHASE CONNECTION - ACTUATOR POWER SUPPLY |
| GREY | PHASE | 24Vac PHASE CONNECTION - ROTATION POINT INVERSION |
| WHITE | 4-20mA | CONNECTION TO THE CONTROL UNIT WITH 4-20mA SIGNAL |
| BLACK | 0-10V | CONNECTION TO THE CONTROL UNIT WITH 0-10Vdc SIGNAL |

4 TECHNICAL FEATURES
ACTUATOR

Actuator type: modulating
 Power supply: 24V - 50Hz
 Absorbed power: 4,5 VA
 Analogic input signal: 0-10V or 4-20mA
 Rotation angle: 90°
 Rotation time: 180s
 Torque: 10 Nm
 Protection degree: IP54
 Cable length: 1m
 Working temperature: -10°C / +50°C

VALVE

Valve body: UNI EN 12165:98 CW617N Brass
 Control stem: UNI EN 12164:98 CW614N Brass
 Sealing gaskets: anti-blockage system with OR in EPDM and seats in PTFE
 Nominal working pressure: 16 bar
 Differential maximum pressure: 5 bar
 Circulating fluid temperature: -5°C (with antifreeze) +100°C
 Available fluids: water, water with glycol